



COMMERCIAL CONTRACTOR GUIDE

ARCHITECTURAL SLABS • PEDESTAL SYSTEMS
PERMEABLE PAVERS • STANDARD PAVERS

VOLUME 28



A BRIEF INTRODUCTION

Pavingstone Supply is Seattle's premier hardscape retailer, a Pacific Northwest institution since 1996. In 2023, Ballard native Michael Marian took ownership of the company, bringing over 25 years of construction industry expertise. We offer top-tier products sourced from the best manufacturers. From concrete pavers and architectural slabs to retaining walls and natural stone, we can accommodate residential and commercial projects of all sizes.



We Deliver!

We deliver to the greater Pacific Northwest and can accommodate up to 14 pallets in a single delivery. *For a limited time, we are offering free delivery for deliveries of 10+ pallets.*

We're also happy to provide free custom quotes for any of your upcoming projects!

4401 11TH AVE NW
SEATTLE, WA 98107

(206) 783-2811
INFO@PAVINGSTONESUPPLY.COM
PAVINGSTONESUPPLY.COM



ARCHITECTURAL SLABS

Architectural slabs span and are compatible with Pedestal Systems

PAGES 1 - 4



PEDESTAL SYSTEMS

PAGES 5 - 6



PERMEABLE PAVERS

PAGES 7 - 8

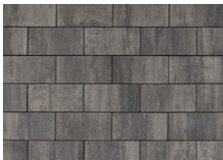

STANDARD PAVERS

PAGE 9



ARTIFICIAL TURF

PAGES 10 - 12



NATURAL STONE

PAGES 13 - 14



BAGGED & BULK SAND, GRAVEL & ROCKS KITS

PAGE 15



DIMENSIONAL FLAGSTONE, STEPS & TREADS HARDSCAPE ACCESSORIES RETAINING WALL SYSTEMS

PAGE 16

ARCHITECTURAL SLABS

OLYMPIC PAVERS

BY: CASTOHN



Natural



Charcoal

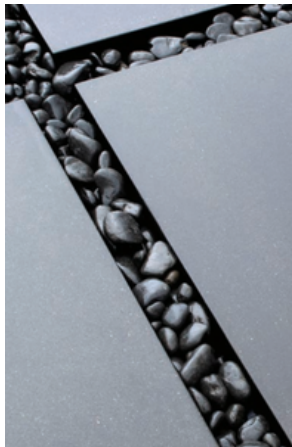

SIZE	SQ FT/ PIECE	SQ FT/ PALLET	PIECES/ PALLET	SHIPPING WEIGHT	WEIGHT/ PIECE
12" x 24" x 2-1/2"	2	64	32	1,970 lbs	61 lbs
12" x 36" x 2-1/2"	3	72	24	2,150 lbs	92 lbs
12" x 48" x 2-1/2"	4	96	24	2,920 lbs	122 lbs
18" x 36" x 2-1/2"	4.5	72	16	2,120 lbs	132 lbs
24" x 24" x 2-1/2"	4	64	16	1,970 lbs	122 lbs
24" x 36" x 2-1/2"	6	48	8	1,520 lbs	184 lbs
24" x 48" x 2-1/2"	8	64	8	2,000 lbs	245 lbs
36" x 36" x 2-1/2"	9	72	8	2,220 lbs	277 lbs



Pallet 12" x 24"



Pallet 12" x 36"



Pallet 12" x 48"



Pallet 18" x 36"



Pallet 24" x 24"



Pallet 24" x 36"



Pallet 24" x 48"



Pallet 36" x 36"

MOUNTAIN SLATE PAVERS

BY: CASTOHN



Natural



Charcoal

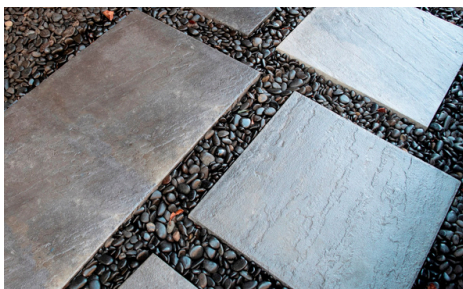

SIZE	SQ FT/ PIECE	SQ FT/ PALLET	PIECES/ PALLET	SHIPPING WEIGHT	WEIGHT/ PIECE
12" x 24" x 2-1/2"	2	64	32	1,970 lbs	61 lbs
12" x 36" x 2-1/2"	3	72	24	2,150 lbs	92 lbs
12" x 48" x 2-1/2"	4	96	24	2,920 lbs	122 lbs
18" x 36" x 2-1/2"	4.5	72	16	2,120 lbs	132 lbs
24" x 24" x 2-1/2"	4	64	16	1,970 lbs	122 lbs
24" x 36" x 2-1/2"	6	48	8	1,520 lbs	184 lbs
24" x 48" x 2-1/2"	8	64	8	2,000 lbs	245 lbs
36" x 36" x 2-1/2"	9	72	8	2,220 lbs	277 lbs



Pallet 12" x 24"



Pallet 12" x 36"



Pallet 12" x 48"



Pallet 18" x 36"



Pallet 24" x 24"



Pallet 24" x 36"



Pallet 24" x 48"



Pallet 36" x 36"

ARCHITECTURAL SLABS

MANHATTAN VIBROPRESSED SLABS

BY: NEWSTONE GROUP

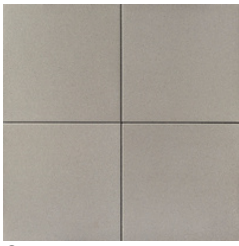

Gray



Charcoal



Winter Sky

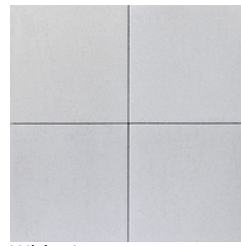

White*



Espresso*

SIZE	SQ FT/ PIECE	SQ FT/ PALLET	PIECES/ PALLET	SHIPPING WEIGHT	WEIGHT/ PIECE
12" x 24" x 2"	2	88	44	2,200 lbs	50 lbs
18" x 18" x 2"	2.25	99	44	2,454 lbs	56 lbs
18" x 36" x 2"	4.5	99	22	2,454 lbs	112 lbs
24" x 24" x 2"	4	88	22	2,200 lbs	100 lbs
24" x 36" x 2"	6	132	22	3,246 lbs	148 lbs
12" x 24" x 3.15" **	2	56	28	2,150 lbs	77 lbs
24" x 24" x 3.15" **	4	56	14	2,150 lbs	154 lbs



* Special order item

** Special order item | Dorado XL - only available in Natural, Charcoal, Winter Sky

HAMPTON VIBROPRESSED SLABS

BY: NEWSTONE GROUP



Gray

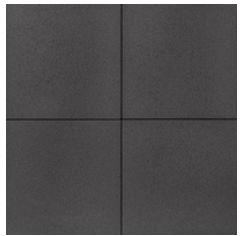

Charcoal

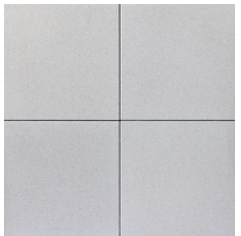

White

SIZE	SQ FT/ PIECE	SQ FT/ PALLET	PIECES/ PALLET	SHIPPING WEIGHT	WEIGHT/ PIECE
12" x 24" x 2"	2	88	44	2,200 lbs	50 lbs
18" x 18" x 2"	2.25	99	44	2,454 lbs	56 lbs
24" x 24" x 2"	4	88	22	2,200 lbs	100 lbs
24" x 36" x 2"	6	132	22	3,246 lbs	148 lbs



ARTERRA PORCERLAIN PAVERS*

by: MSI



SIZE	SQ FT/ PIECE	SQ FT/ BOX	PIECES/ BOX	WEIGHT/ PIECE	WEIGHT/ BOX	ORDER REQUIREMENTS
24" x 24" x 2cm	4	8	2	38 lbs	72 lbs	Sold in pairs

*Special order item | Available in various colors | Pallet size varies

ARCHITECTURAL SLABS

TEXADA

BY: BELGARD



Gray

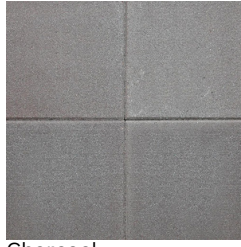

Charcoal



SIZE	SQ FT/ PIECE	SQ FT/ PALLET	PIECES/ PALLET	SHIPPING WEIGHT	WEIGHT/ PIECE
18" x 18" x 1-5/8"	2.25	135	60	2,900 lbs	48 lbs
12" x 24" x 2"	2	96	48	2,300 lbs	48 lbs
24" x 24" x 2"	4	100	25	2,400 lbs	96 lbs

VANCOUVER BAY

BY: MUTUAL MATERIALS

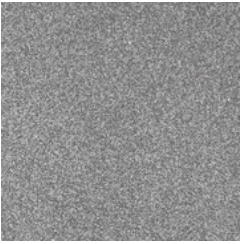

Gray (12x24, 24x24)
Platinum (18x18)

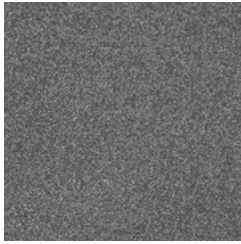

Charcoal (12x24, 24x24)
Graphite (18x18)



Latte* (18x18, 12x24,
24x24)

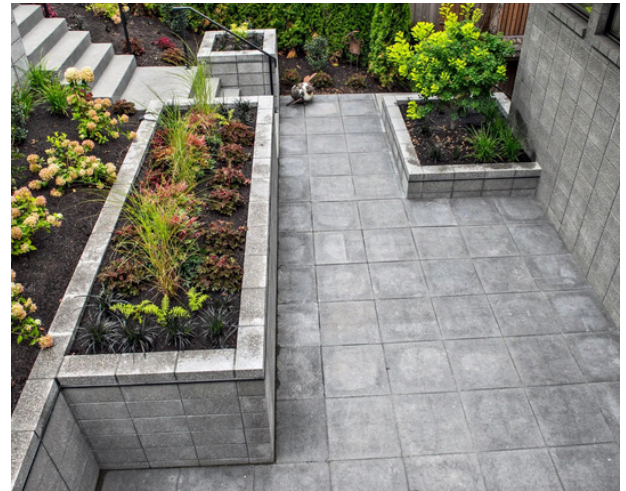

SIZE	SQ FT/ PIECE	SQ FT/ PALLET	PIECES/ PALLET	SHIPPING WEIGHT	WEIGHT/ PIECE
18" x 18" x 1-3/8"	2.25	126	56	2,626 lbs	45 lbs
12" x 24" x 1-3/4"	2	112	56	2,570 lbs	45 lbs
24" x 24" x 1-3/4"	4	112	24	2,210 lbs	90 lbs

* Special order item

GLACIER SLATE

BY: MUTUAL MATERIALS



Gray



Charcoal



Black Diamond*



Latte*



SIZE	SQ FT/ PIECE	SQ FT/ PALLET	PIECES/ PALLET	SHIPPING WEIGHT	WEIGHT/ PIECE
24" x 24" x 1-3/4"	4	112	24	2,210 lbs	90 lbs

* Special order item

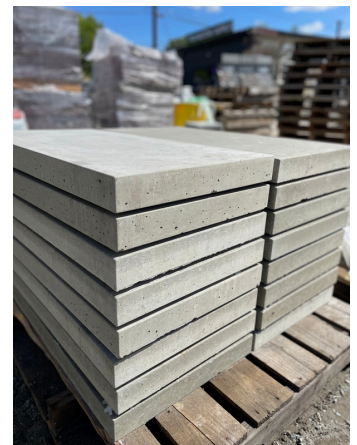

PEDESTAL SYSTEMS

BLACKJACK PEDESTAL

BY: BLACKJACK



HALF STEP PEDESTAL

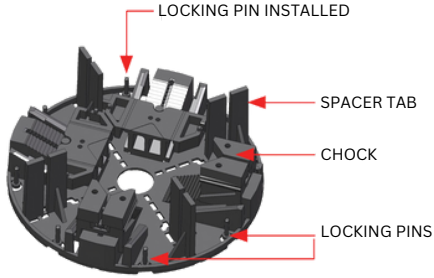

ONE STEP PEDESTAL

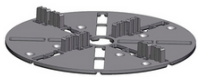

4MM PEDESTAL

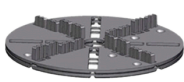

4MM PEDESTAL
STACK TO CREATE
8MM PEDESTAL



4MM PEDESTAL
REMOVE 1/4 FOR
CORNER APPLICATION



4MM PEDESTAL
REMOVE 1/2 FOR
EDGE APPLICATION

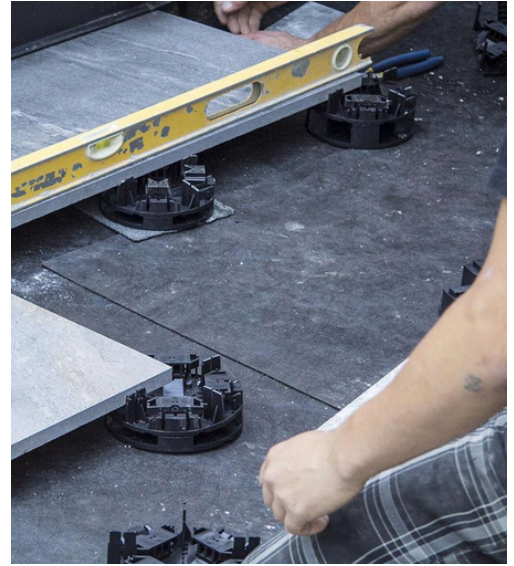

UNIT	HEIGHT ADJUSTMENTS		UNITS/PACKAGE	FEATURES
HALF STEP PEDESTAL	0.47" - 0.94"	(12 - 24MM)	66/BAG	Independent chock adjustments can be made in 1mm increments Height adjustments can be locked in place using attached locking pins Stack two 4mm pedestals to create an 8mm pedestal Has four 1" (24MM) raised supports on which "snap in" movable chocks are positioned Has four 1" (24MM) raised supports on which "snap in" movable chocks are positioned
ONE STEP PEDESTAL	0.95" - 1.77"	(24 - 45MM)	40/BAG	
4MM PEDESTAL	0.16"	(4MM)	200/BOX	
20MM EXTENDER	0.79"	(20MM)	76/BOX	
40MM EXTENDER	1.57"	(40MM)	40/BOX	



20MM EXTENDER

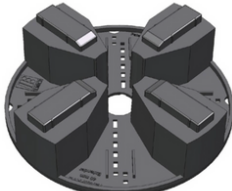

40MM EXTENDER



PEDESTAL SYSTEMS

DIAMOND HEAD SERIES PEDESTAL

BY: AWS

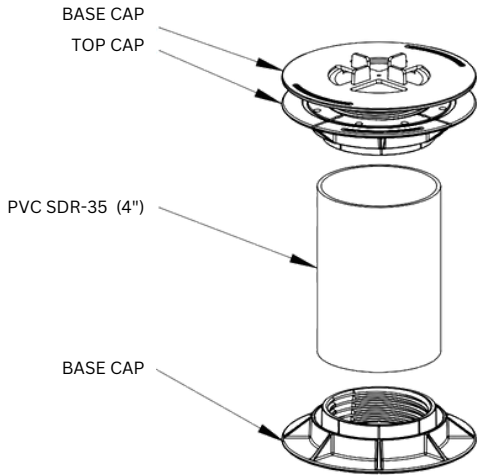

SIZE

- 2 PIECE ADJUSTABLE PEDESTAL
- 3 PIECE ADJUSTABLE PEDESTAL
- PEDESTAL SLOPE COMPENSATION
- PEDESTAL BASE CAP
- PEDESTAL TOP CAP

HEIGHT ADJUSTMENTS

- 1-3/8" - 2-1/4" (35 - 57MM)
- 2-3/8" - 24" (60 - 610MM)
- 2% SLOPE ADJUSTMENT
- N/A
- N/A

COMPONENTS

- (1) PEDESTAL BASE CAP + (1) PEDESTAL TOP CAP
- (2) PEDESTAL BASE CAPS + (1) PEDESTAL TOP CAP
- SINGLE UNIT | 200/BOX
- SINGLE UNIT | 100/BAG
- SINGLE UNIT | 100/BAG

FEATURES

- NOT FOR USE WITH PVC
- FOR USE WITH STANDARD 4" SDR 34 PVC
- CAN BE STACKED TO INCREASE SLOPE
- 6-5/8" DIAMETER TO SUPPORT BALANCE
- BUILT IN 1/8" SPACER TABS

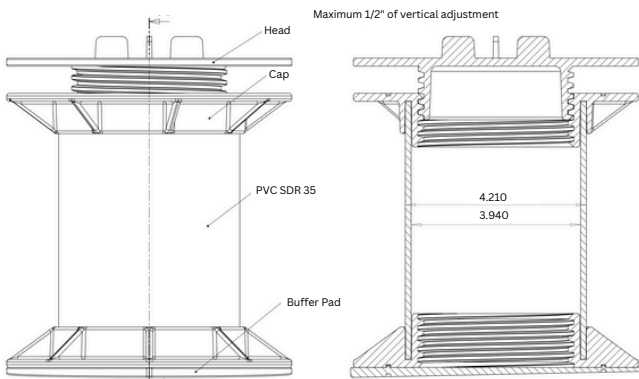

3 PIECE ADJUSTABLE PEDESTAL

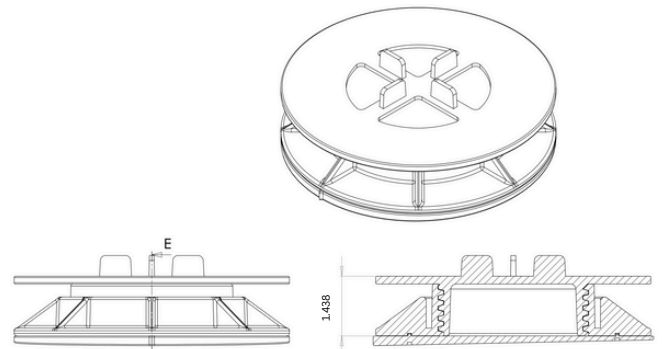

2 PIECE ADJUSTABLE PEDESTAL

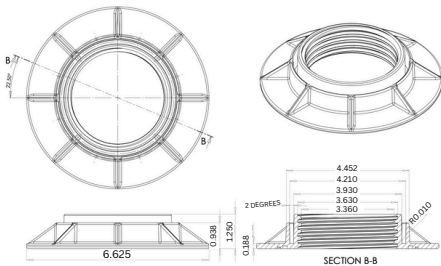

PEDESTAL END CAP

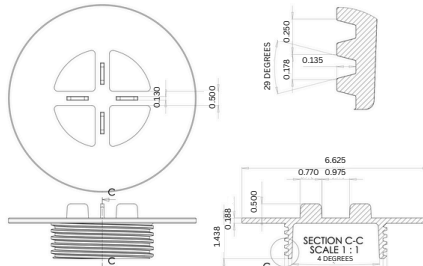

PEDESTAL TOP CAP

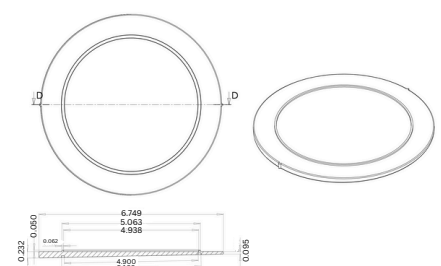

2% SLOPE CORRECTOR

PERMEABLE PAVERS

ECO PRIORA

BY: MUTUAL MATERIAL



Gray

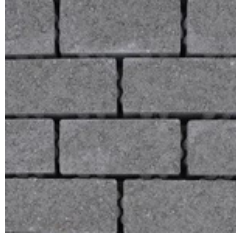

Charcoal



SIZE	PIECES/ SQFT	SQ FT/ PALLET	PIECES/ PALLET	SHIPPING WEIGHT	WEIGHT/ PIECE	OPEN SURFACE AREA
4" x 8" x 3-1/8"	4.5	93.2	432	3,456 lbs	8 lbs	13%
8" x 8" x 3-1/8"	2.25	83.04	192	3,172 lbs	16 lbs	9%

AQUALINE

BY: BELGARD



Gray



Charcoal

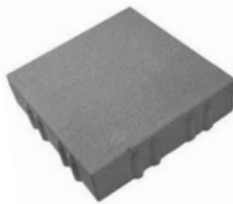

SIZE	PIECES/ SQFT	SQ FT/ PALLET	PIECES/ PALLET	SHIPPING WEIGHT	WEIGHT/ PIECE	OPEN SURFACE AREA
Half 4.5" x 9" x 3-1/8"	3.6	90	320	3,155 lbs	10 lbs	12%
Full. 9" x 9" x 3-1/8"	1.8	90	160	3,245 lbs	20 lbs	12%

PERMEABLE PAVERS

TURF STONE

BY: WESTERN INTERLOCK

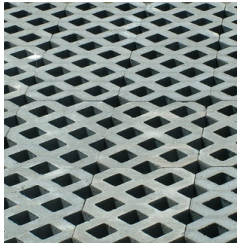

Gray



SIZE	PIECES/ SQFT	SQ FT/ PALLET	PIECES/ PALLET	SHIPPING WEIGHT	WEIGHT/ PIECE	OPEN SURFACE AREA
9" x 12" x 3-1/8"	1.33	79	105	2,080 lbs	20 lbs	25%

DORADO DRAIN PAVER

BY: NEWSTONE GROUP



Natural



Charcoal

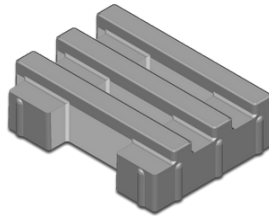

SIZE	PIECES/ SQFT	SQ FT/ PALLET	PIECES/ PALLET	SHIPPING WEIGHT	WEIGHT/ PIECE	OPEN SURFACE AREA
9" x 12" x 3-1/8"	1.33	79	105	2,080 lbs	20 lbs	25%

CAMINO PERMEARE

BY: WESTERN INTERLOCK



Cambridge



Columbia



Jamestown

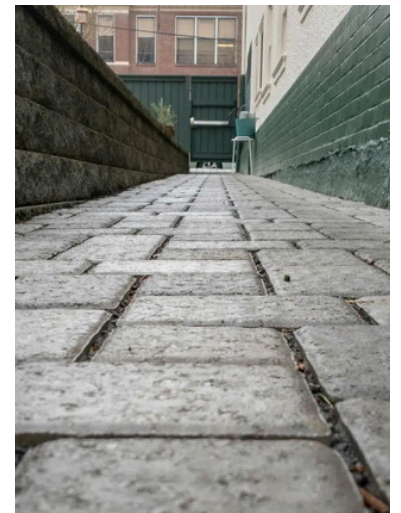

SIZE	PIECES/ SQFT	SQ FT/ PALLET	PIECES/ PALLET	SHIPPING WEIGHT	WEIGHT/ PIECE	OPEN SURFACE AREA
Square 6.22" x 6.22" x 2.36"	3.65	103.6	378	2,770 lbs	7.3 lbs	6.7%
Rectangle 6.22" x 9.37" x 2.36"	2.42	111.5	270	2,920 lbs	10.9 lbs	5.8%

STANDARD PAVERS

STANDARD

BY: NEWSTONE GROUP



Gray Charcoal Shadow



SIZE	PIECES/ SQFT	SQ FT/ PALLET	PIECES/ PALLET	SHIPPING WEIGHT	WEIGHT/ PIECE
4.5" x 4.5" x 2-3/8" (Half Standard)	7.2	98	720	2,700 lbs	3.75 lbs
4.5" x 9" x 2-3/8" (Standard)	3.6	98	360	2,700 lbs	7.5 lbs
9" x 9" x 2-3/8" (Double Standard)	1.8	98	180	2,700 lbs	15 lbs

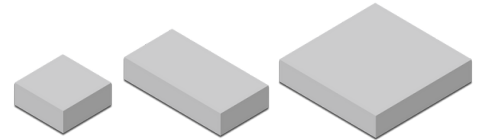

DORADO

BY: NEWSTONE GROUP



Gray Charcoal Shadow Espresso*

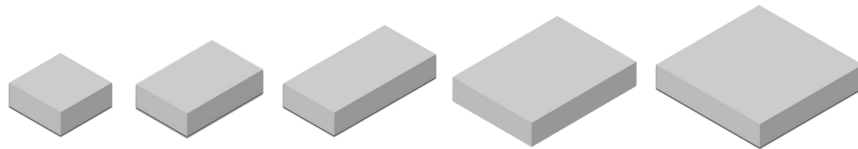

SIZE	PIECES/ SQFT	SQ FT/ PALLET	PIECES/ PALLET	SHIPPING WEIGHT	WEIGHT/ PIECE
6" x 6" x 2-3/8"	4	60	240	1,675 lbs	7 lbs
6" x 9" x 2-3/8"	2.67	101.25	270	2,930 lbs	11 lbs
6" x 12" x 2-3/8"	2	108	216	3,000 lbs	14 lbs
9" x 12" x 2-3/8"	.133	101.25	135	2,930 lbs	22 lbs
12" x 12" x 2-3/8"	1	108	108	3,000 lbs	28 lbs

* Special order item

HOLLAND

BY: MUTUAL MATERIALS



Cascade Onyx Summit NW

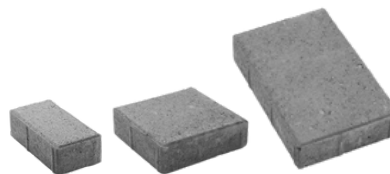

SIZE	PIECES/ SQFT	SQ FT/ PALLET	PIECES/ PALLET	SHIPPING WEIGHT	WEIGHT/ PIECE
4" x 8" x 2-3/8" (Holland)	4.63	104.88	486	2,966 lbs	6 lbs
8" x 8" x 2-3/8" (Double Holland)	2.31	93.46	216	2,642 lbs	12 lbs
8" x 12" x 2-3/8" (Triple Holland)	1.57	92	144	2,650 lbs	18 lbs

ARTIFICIAL TURF

EVERGRASS™ TURF ✦

BY: MSI

With exclusive BioLuxe™ Worry-Proof Technology, these Evergrass™ Turf options incorporate built-in antimicrobial and odor-control features, making it a safe haven for children and pets.

With a rapid drainage rate of 280 inches per hour, you can enjoy worry-free outdoor moments, even in the PNW rainfall.

Evergrass® is backed by a lifetime limited residential and 10-year commercial warranty, giving you extra peace of mind.

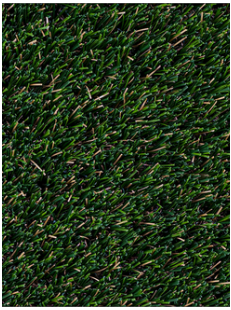

SUMMER GOLD 96



VIRIDIAN TURF 91

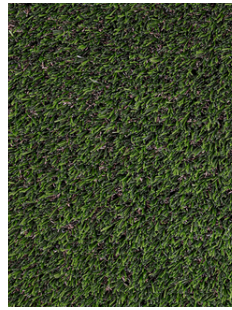

MEADOW GREEN PET-TURF 91



PUTTING GREEN TURF 78

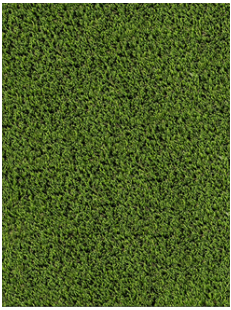

EMERALD GREEN TURF 110



EMERALD GREEN TURF 76



EMERALD TURF PRE-CUT 81



Evergrass™ Artificial Turf

Base Layer

4'-6" of compacted, crushed gravel that varies in size from 3/8" to dust

Existing Soil

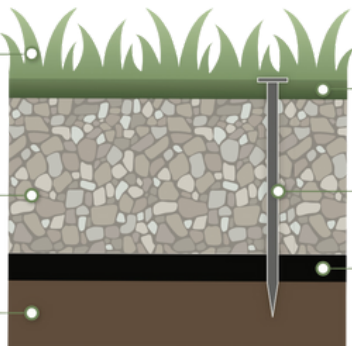

Infill

Secure the turf by nailing the edges with 6" nails

Weed Barrier

BIOLUXE™ WORRY-PROOF TECHNOLOGY



Antimicrobial - Fights Against Odor



Warranty - Lifetime Residential



Warranty - 10-Year Commercial



Fast Drainage



Realistic Look



Safe for Kids & Pets



Virtually No Maintenance

*All Evergrass™ Turf products are special order items

ARTIFICIAL TURF

EVERGRASS™ TURF | SUMMER GOLD 96

BY: MSI



PILE HEIGHT	1.75" (45MM)
FACE WEIGHT	70 OZ / SQ YD
TOTAL WEIGHT	96 OZ
TUFTING GUAGE	3/8"
DRAINAGE RATE	280" / HOUR
LENGTH X WIDTH	100' LONG X 15' WIDE
BLADE SHADE	C & DIAMOND

EVERGRASS™ TURF | VIRIDIAN TURF 91

BY: MSI



PILE HEIGHT	1.75" (45MM)
FACE WEIGHT	65 OZ / SQ YD
TOTAL WEIGHT	91 OZ
TUFTING GUAGE	3/8"
DRAINAGE RATE	280" / HOUR
LENGTH X WIDTH	100' LONG X 15' WIDE
BLADE SHADE	W

EVERGRASS™ TURF | MEADOW GREEN PET-TURF 91

BY: MSI



PILE HEIGHT	1.18" (30MM)
FACE WEIGHT	65 OZ / SQ YD
TOTAL WEIGHT	91 OZ
TUFTING GUAGE	3/8"
DRAINAGE RATE	280" / HOUR
LENGTH X WIDTH	100' LONG X 15' WIDE
BLADE SHADE	DOUBLE S

DVERGRASS™ TURF | PUTTING GREEN TURF 78

BY: MSI



PILE HEIGHT	0.63" (16MM)
FACE WEIGHT	50 OZ / SQ YD
TOTAL WEIGHT	78 OZ
TUFTING GUAGE	3/16"
DRAINAGE RATE	140" / HOUR
LENGTH X WIDTH	100' LONG X 15' WIDE
BLADE SHADE	-

ARTIFICIAL TURF

EVERGRASS™ TURF | EMERALD GREEN TURF 110

BY: MSI

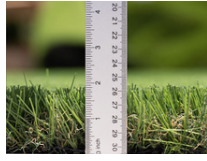

PILE HEIGHT	1.75" (45MM)
FACE WEIGHT	84 OZ / SQ YD
TOTAL WEIGHT	110 OZ
TUFTING GAUGE	3/8"
DRAINAGE RATE	280" / HOUR
LENGTH X WIDTH	100' LONG X 15' WIDE
BLADE SHADE	M

EVERGRASS™ TURF | EMERALD GREEN TURF 76

BY: MSI

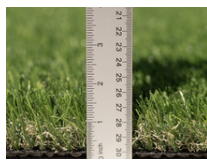

PILE HEIGHT	1.57" (40MM)
FACE WEIGHT	50 OZ / SQ YD
TOTAL WEIGHT	76 OZ
TUFTING GAUGE	3/8"
DRAINAGE RATE	280" / HOUR
LENGTH X WIDTH	100' LONG X 15' WIDE
BLADE SHADE	M

EVERGRASS™ TURF | EMERALD TURF PRE-CUT 81

BY: MSI



PILE HEIGHT	1.1" (28MM), 1.25" (32MM), 1.5" (38MM)
FACE WEIGHT	140 OZ / SQ YD
TOTAL WEIGHT	81 OZ
TUFTING GAUGE	3/8"
DRAINAGE RATE	280" / HOUR
LENGTH X WIDTH	6' X 8'
BLADE SHADE	C & DIAMOND

EVERGRASS™ TURF | ACCESSORIES

BY: MSI



5D TURF NAILS (5")

SOLD BY BOX	50 LBS
BOXES / PALLET	48 BOXES
COVERAGE / BOX	800 SQ FT



ULTRABOND LANDSCAPE SEAM TAPE 12" x 100"

SOLD BY ROLL	100' LINEAR
ROLLS / BOX	4 BOXES
COVERAGE / ROLL	100' LINEAR



WONDERFILL GREEN 12/20 SAND

SOLD BY BAG	50 LBS
BAGS / PALLET	56 BAGS
COVERAGE / BAG	VARIES BY TURF



GA LANDSCAPE STAPLES 1" x 6" (11 GAUGE)

SOLD BY BOX	100 STAPLES
BOXES / PALLET	10 BOXES
COVERAGE / BOX	50' LINEAR



CG SYNTHETIC TURF ADHESIVE 1 GALLON

SOLD BY BUCKET	1 GALLON
BUCKETS / PALLET	36 BUCKETS
COVERAGE / BUCKET	80 SQ FT

TURF INFILL*

	LBS / SQ FT	500 SQ FT	1,000 SQ FT
Emerald Green 76	2.5	25 bags	50 bags
Viridian Turf 91	2	20 bags	40 bags
Emerald Green 110	1.5	15 bags	30 bags

*approximate coverage

NATURAL STONE



BAKER SMALL PATIO 1" - 2"



BAKER STANDARD PATIO 2"
(2" - 3" PATIO AVAILABLE)



BAKER LEDGE STONE

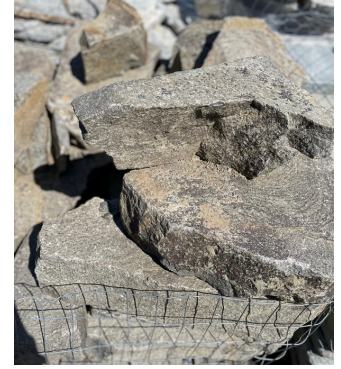

BAKER MOLALLA ONE MAN WALL
(2 - 4" DRY STACK WALL STONE
AVAILABLE)



COWBOY COFFEE PATIO 1 - 1.5"
(STANDUP PATIO 1.5" - 2" AVAILABLE)



COWBOY COFFEE TUMBLED PATIO
1.5" - 2"



COWBOY COFFEE LEDGE STONE
1.5" - 2"



COWBOY COFFEE DRY STACK
WALL STONE



GLACIER GREEN PATIO 1" - 2"



GLACIER GREEN POP UP
(8" 12" LEDGE STONE AVAILABLE)



GOLD RUSH PATIO 1" - 1.5"



GOLD RUSH LEDGE STONE



INDIAN PAINTBRUSH PATIO
(TUMBLED PATIO AVAILABLE)
(STANDUP PATIO 1.5" - 2" AVAILABLE)



INDIAN PAINTBRUSH DRY STACK
WALL STONE
(LEDGE STONE AVAILABLE)



ANTIQUE BLACK 1" FLAGSTONE



SILVER PEARL 1" FLAGSTONE

NATURAL STONE



SILVER STRIKE PATIO 1" - 1.5"



SILVER STRIKE STANDUP 1" - 1.5"



SILVER STRIKE TUMBLED PATIO 1" - 1.5"

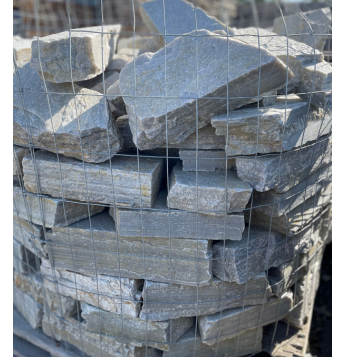

SILVER STRIKE LEDGE STONE
(DRY STACK WALL STONE AVAILABLE)



SOCKEYE PATIO 1" - 1.5"



SOCKEYE TUMBLED PATIO 1" - 1.5"



SOCKEYE LEDGE STONE



SOCKEYE DRY STACK WALL STONE



MONTANA RUSTIC FLAGSTONE 1" - 2"
(3" - 6" LEDGE STONE AVAILABLE)
(9" - 24" WALL STONE AVAILABLE)



PENNSYLVANIA BLUESTONE THICK
RUSTIC GARDEN PATH
(THIN OPTION AVAILABLE)



PENNSYLVANIA BLUESTONE THIN
SAWN GARDEN PATH



PENNSYLVANIA BLUESTONE THICK
SAWN GARDEN PATH



PENNSYLVANIA BLUESTONE



PENNSYLVANIA BLUESTONE
TUMBLED WALL STONE 2" - 6"



PENNSYLVANIA BLUESTONE
TUMBLED BELGIUM WALL STONE 8"



PENNSYLVANIA BLUESTONE
SNAPPED WALL STONE 8"

BAGGED & BULK SAND, GRAVEL & ROCKS*



BUILDERS SAND
BAGS: 50 LB
BULK: BY YARD



1/4" MINUS
BAGS: 50 LB
BULK: BY YARD



3/8" CLEAN CRUSH (8840)
BAGS: 50 LB
BULK: BY YARD

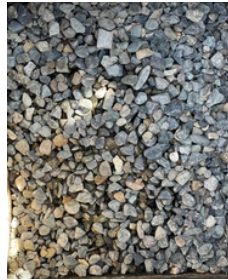

3/8-5/8" CLEAN CRUSH (8820)
BAGS: 50 LB
BULK: BY YARD



5/8" MINUS
BAGS: 50 LB
BULK: BY YARD

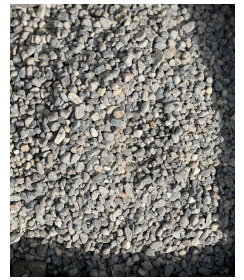

3/8" GREY PEA GRAVEL
BAGS: 50 LB
BULK: BY YARD



7/8" WASH DRAIN
BAGS: 50 LB
BULK: BY YARD



1.5" WASH DRAIN
BAGS: 50 LB
BULK: BY YARD

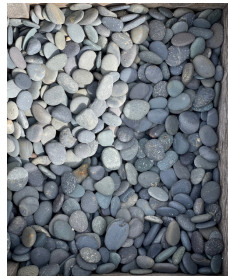

MEXICAN BEACH BUTTONS
BAGS: 40 LB



CHARCOAL PEBBLES
BAGS: 44 LB (3/8") | 44 LB (1/2")



BLACK LAVA ROCK
BAGS: 42 LB (3/4")



RED LAVA ROCK
BAGS: 29 LBS (1/2")



CHINESE WHITE
1/4" | 3/8" | 3/8-5/8"
BAGS: 50 LB | 3,000 LB

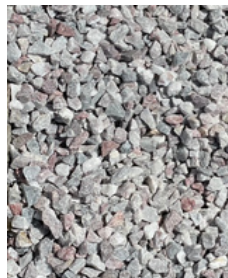

CHAMPAGNE
1/4" | 3/8" | 5/8-1-1/4"
BAGS: 50 LB | 3,000 LB



CHEWELAH
1/4" | 3/8" | 3/8-5/8"
BAGS: 50 LB | 3,000 LB



SALT & PEPPER
1/4" | 3/8" | 3/8-5/8"
BAGS: 50 LB | 3,000 LB



JET BLACK
1/4" | 3/8" | 3/8-5/8"
BAGS: 50 LB | 3,000 LB



3/8" RAINBOW CRUSH
BAGS: 50 LB | 3,000 LB



MSI SEALED BLACK
40 LB BAG: 1/4-1/2" | 1/4-3/4"
3/4-1-1/4" | 1-2" | 2-3-1/2"



BLACK/GREY MEXICAN BEACH ROCK
75 LB BAG: 1/2-1" | 1-2" | 2-3" | 3-5"
BULK BY LB: 3-5" | 4-6" | 8-12"



BUFF MEXICAN BEACH ROCK
75 LB BAG: 1/2-1" | 1-2" | 2-3"
BULK BY LB: 3-5"

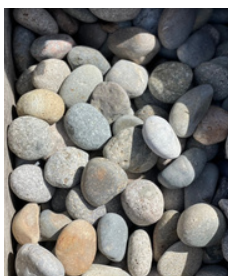

MIXED MEXICAN BEACH ROCK
75 LB BAG: 1/2-1" | 1-2" | 2-3" | 3-5"
BULK BY LB: 3-5" | 8-12"



LARGE CURRAN COBBLES
BULK BY LB: 6-8"

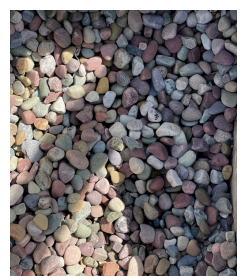

RAINBOW ROUND ROCK
50 LB BAG: 3/8" PEA | 7/8" | 1-1.5"
3,000 LB BAG: 3/8" PEA | 7/8" | 1-1.5"
BULK BY LB: 3" | 3-5" | 6-10"

GRANITE COBBLE*



3.5" X 3.5" X 3.5" GREY



3.5" X 3.5" X 3.5" BLACK



8" X 4" X 2" BLACK



FIREPIT KITS



CIRCLE KITS



FREYER GARDEN TRELLIS
BY: SEATTLE URBAN FARM CO.

DIMENSIONAL STONE, STEPS & TREADS*



DIMENSIONAL PENNSYLVANIA BLUESTONE (THERMAL OPTION AVAILABLE)



DIMENSIONAL TUMBLED PENNSYLVANIA BLUESTONE

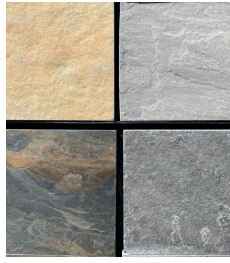

DIMENSIONAL FLAGSTONE (SUI)



PENNSYLVANIA BLUESTONE NURSERY STEPS

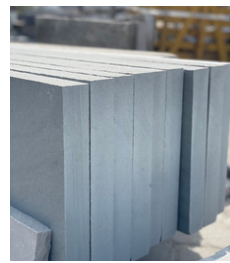

PENNSYLVANIA BLUESTONE THERMAL TREADS



NATURAL STONE TREADS

HARDSCAPE ACCESSORIES*



PAVER EDGING



10" STEEL SPIKES



STEEL EDGING 4"X20"X1/8"



LANDSCAPE EDGING & STAKES



CONSTRUCTION ADHESIVE



SLAB GRABBERS (MULTIPLE DIMENSIONS)



SEALING & CLEANING PRODUCTS BY: DRY TREAT



SEALING & CLEANING PRODUCTS BY: GST



LANDSCAPE FABRIC & STAPLES



GEO-GRID & GEO-TEXTILE



JOINTING SANDS (LOOSE, PERMEABLE & POLYMERIC)

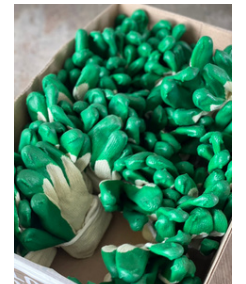

WORK GLOVES

RETAINING WALL SYSTEMS*



CORNERSTONE BY: MUTUAL MATERIALS



MANORSTONE BY: MUTUAL MATERIALS

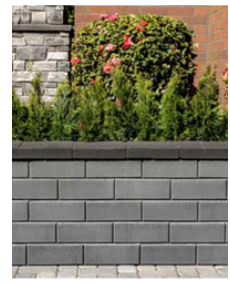

MANORSTONE ELITE BY: MUTUAL MATERIALS



STACKSTONE BY: MUTUAL MATERIALS



DIAMOND PRO BY: BELGARD

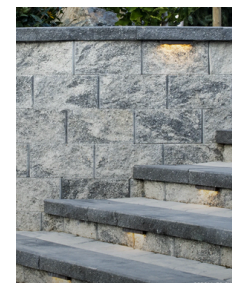

GARDEN WALLSCAPE BY: BELGARD



MURUTA BY: WESTERN INTERLOCK



CHATEAU MODERNA BY: WESTERN INTERLOCK

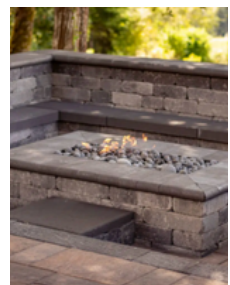

CHATEAU BY: WESTERN INTERLOCK



KODAH BY: CASTOHN



DIMENSIONAL BY: CASTOHN

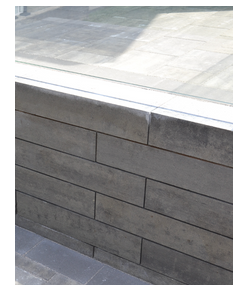

DORADO BY: NEWSTONE GROUP

* NOT A COMPREHENSIVE LIST OF ITEMS STOCKED/SOLD



PAVINGSTONE SUPPLY

- IN STOCK ITEMS -

CONCRETE PAVERS
ARCHITECTURAL SLABS
PERMEABLE PAVERS
PEDESTAL SYSTEMS
RETAINING WALL SYSTEMS
STEPS & TREADS
NATURAL FLAGSTONE, LEDGE STONE & WALL STONE
BASE GRAVEL, ROCK & SAND (BAGGED & BULK)
DECORATIVE GRAVEL & ROCKS (BAGGED & BULK)
LOOSE, PERMEABLE & POLYMERIC JOINTING SANDS
ARTIFICIAL TURF
LANDSCAPE EDGING & STAKES
PAVER EDGING & SPIKES
GEO GRID & GEO TEXTILE
LANDSCAPE FABRIC & STAPLES
CLEANERS (CONCRETE & NATURAL STONE)
SEALERS (CONCRETE & NATURAL STONE)
GARDEN TRELIS SYSTEM
WORK GLOVES
SLAB GRABBERS
EQUIPMENT RENTALS

**4401 11TH AVE NW
SEATTLE, WA 98107**

**(206) 783-2811 | INFO@PAVINGSTONESUPPLY.COM
PAVINGSTONESUPPLY.COM**